

ABANAKI

The *Oil Viper* Tube Skimmer

The Abanaki *Oil Viper* tube skimmer effectively removes floating surface oils by means of a oleophilic (oil attracting) 3/4 inch diameter continuous looped tube. The tube extends out over the surface of the tank or pit and collects the free floating oils.

The *Oil Viper's* specially designed wiper mechanism uses an o-ring wiper attached to the tube along with an additional ceramic wiper on the skimmer to remove the collected oil from the tube. The result is a virtually oil free tube as it returns to the water for quicker oil removal. Removal rates can be as high as 100 gallons per hour.

The unit is powered by a fractional horse power TEFC in any voltage configuration. Explosion proof and wash down duty motors are available. An automatic shutoff switch turns the skimmer off when the cover is in the open position for safe and easy maintenance. The tube is available in lengths up to one hundred feet. Predrilled mounting holes in the bottom of the unit for easy mounting to any flat surface.

The *Oil Viper* is designed to remove all types of oil, making it perfect for use in any industrial or food processing industry where free floating oil is present.

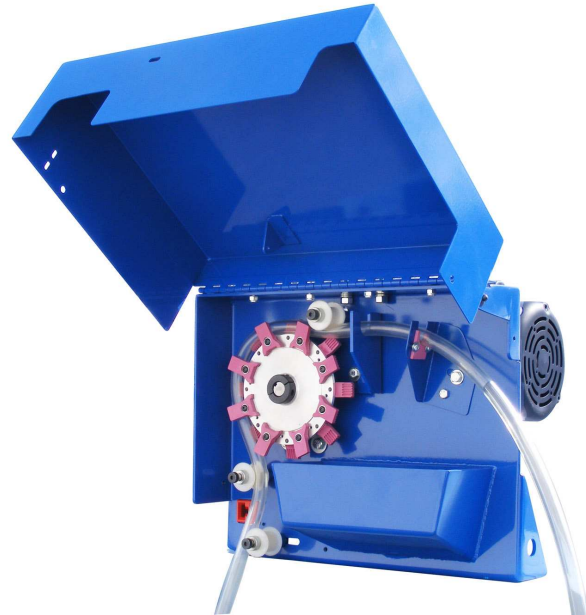

Key Features:

- Compact design fits almost any tank or pit.
- Explosion proof and wash down duty motors available.
- Tubes with up to 100 foot reach.
- Safety shut off switch for safe maintenance.
- Simple and effective drive design for lasting performance.
- Unique wiping system for more effective oil removal.
- Weighs 74 pounds.
- Units with removal rates of up to 100 gph.

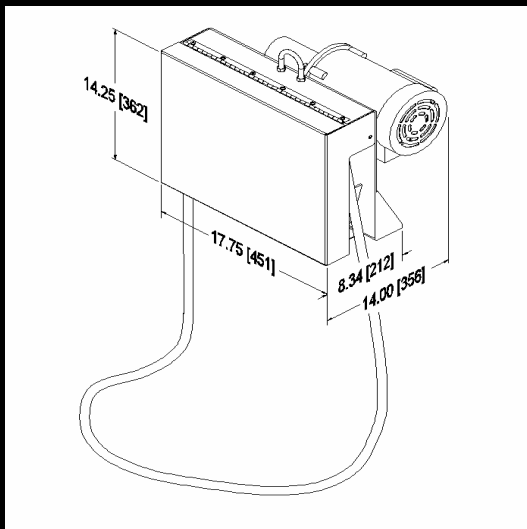

ABANAKI
CORPORATION
17387 Munn Road
Chagrin Falls, OH 44023
Phone: (440) 543-7400
Fax: (440) 543-7404
1-800-358-SKIM (7546)
www.abanaki.com

ABANAKI

Oil skimming makes use of the differences in specific gravity between oil and water. These physical characteristics allow the tube to attract oil and other hydrocarbon liquids from the surface of the fluid. The *Oil Viper* can be used in tanks with depths as shallow as a few inches, or reach as far as 100 feet.

Where To Use The *Oil Viper*

The *Oil Viper* is a compact, versatile Abanaki skimmer. Its size and removal capacity make it suitable for most applications. From a mere shimmer on top of water to a heavy oil slick, the *Oil Viper* performs efficiently, removing up to 100 gallons of oil per hour.

Typical Applications

- Wastewater sumps
- Coolant systems
- Food processing plants
- Parking lots, garages and service facilities
- Outdoor ponds, lakes and basins
- Underground tanks
- Ships bilges
- Aircraft service areas and tarmac runoff
- Truck, locomotive and other mobile equipment washing facilities
- Steel Manufacturing Plants

Rugged Construction for Harsh Conditions

The *Oil Viper* is designed to last for many years. With the proper configuration it can handle liquid temperatures up to 212°F, and the pH of the fluid can range from 3 to 13.

The skimmer drive includes an oil filled gear reducer with bronze gears and ball bearings. The motor, gear reducer, and powder coated finish of the weldments give the *Oil Viper* exceptionally long life, even under the harshest conditions.

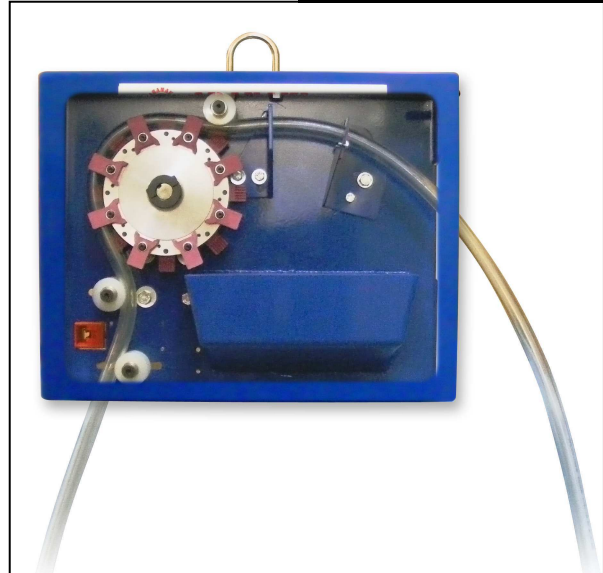

Key Features of the *Oil Viper*:

- Requires only a small area in the tank or sump
- Easy mounting
- High temperature capability
- Chip resistant powder finish
- Carbon Steel or Stainless Steel Construction
- Custom designs and turnkey systems available
- Fast cleaning with minimal maintenance



TubeTastic! Series

Oil Viper

Abanaki's Oil Concentrators®

The Oil Concentrator® is an option available on almost all ABANAKI oil skimmers. Under Most operating conditions ABANAKI oil skimmers will pick up oil with less than 5% water. But as surface oil is reduced to a thin layer (1/16 to 1/8 inch thick), more water or coolant may also be picked up along with the oil. When used in tandem with the oil skimmer, an Oil Concentrator will solve this problem, and provides virtually complete oil/water separation, saving money and improving the efficiency of the skimmer.

Based on the principle of gravity separation, the Oil Concentrator uses no electricity, timers, sensors, pumps, or other moving parts. The Oil Concentrator sits behind the skimmer and receives its discharged oil. The unit comes complete with a mounting bracket, removable sludge screen and a drain plug to ease clean up. For higher viscosity oils or low temperature applications, a thermostatically controlled heater is available as an option.

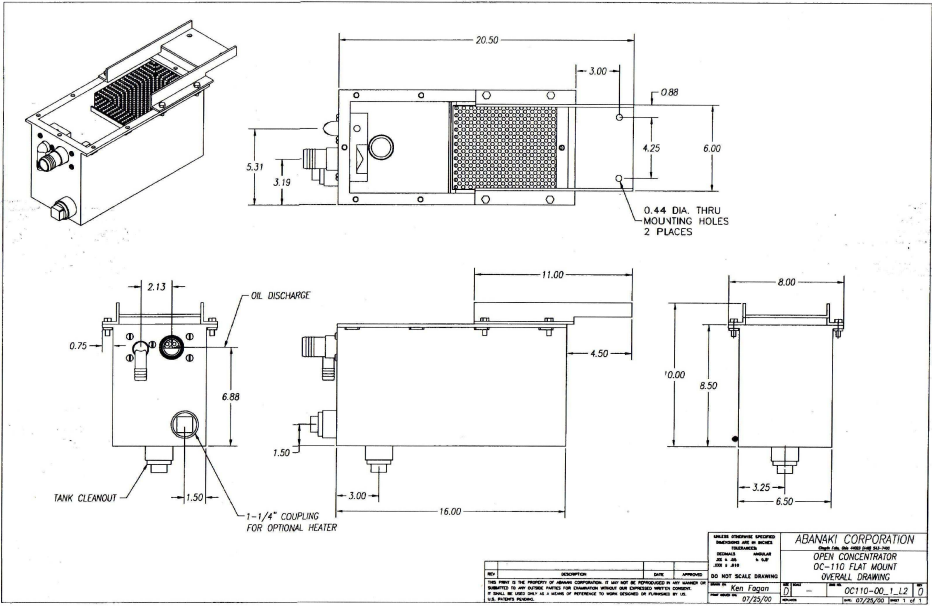
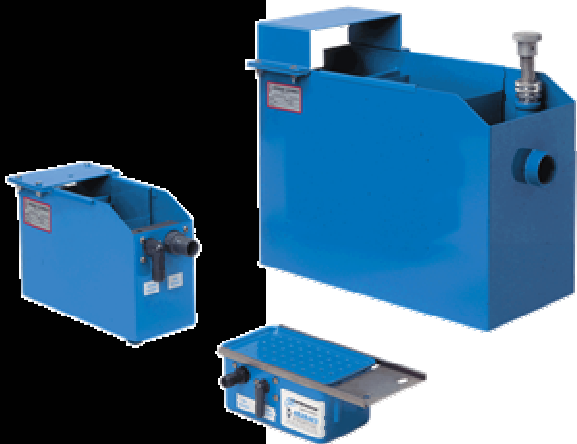

TubeTastic! Series

Oil Viper Tube Skimmer

Abanaki has thousands of skimmers installed worldwide at leading companies such as...

American Cyanamid	Kaiser Aluminum
Armstrong World Industries	Lockheed
Bethlehem Steel	Mazak
Boeing	Monroe Auto Equipment
British Steel	New York Power Authority
Bureau of Reclamation	Nissan Motor
Caterpillar	Norfolk Southern Railroad
Chevron	Nucor-Yamato Steel
Corning	Outboard Marine
Dow Chemical	TRW
Eaton	Union Pacific Railroad
Flying J	United Airlines
Ford Motor	USS Great Lakes Fleet
General Electric	Volvo AB
Henry Filters	Wartsila Diesel
Honda	Westinghouse Electric
John Deere	

Other Oil Skimming Products From Abanaki

Model 4[®]

For Most Applications
Single 8-inch wide belt (20.3 cm)
Any length belt
Capacity: 40 GPH (151.4 LPH)

Model MB[®]

For High Volume
Two to five 8-inch belts (20.3 cm)
Any length belts
Capacity: to 200 GPH (757.1 LPH)

Tote-It[®] Portable

Portable for Moderate Capacity Applications
Single belt: 2-inch or 4-inch (5.1 or 10.2 cm)
Belt length: 1' - 6" to 5'-0" (45.2 to 152.4 cm)
Capacity: 6 GPH - 2" belt (15.1 LPH - 5.1 cm belt)
12 GPH - 4" belt (22.7 LPH - 10.2 cm belt)

Mighty Mini[®]

Small Applications (Parts Washers, CNC Machines, 55 Gal. Drums)
Single belt: 1-inch or 2-inch (25.4 or 50.8 mm)
Belt length: 6", 12", 18", 24" (153, 305, 458, 610 mm)
Capacity: 1 GPH - 1" belt (3.81 LPH)
2 GPH - 2" belt (5.71 LPH)

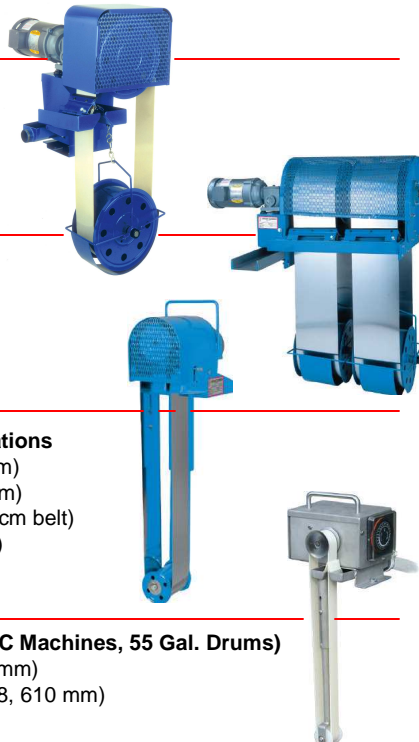

Specifications:

Oil Removal Rate Up to 100 gph (378 lph).
Rate is based on 30 weight oil in water at ambient temperature.

Motor Fractional hp, TEFC, gear motor operating on either 115/230VAC, single phase, 60Hz or 230/460VAC, three phase, 60Hz.
Optional: 50Hz power source; explosion proof; drip proof; pneumatic; and WD duty.

Tube Dia. 3/4" O.D. (2 cm)

Tube Length Up to 100 (30 m) foot reach.

Tube Material Standard synthetic material for wastewater applications not involving high temperature or chemical applications.
Rough service synthetic material for higher temperature and chemical applications.

Wiper Nitrile & ceramic wiping system completely removes the oil collected on the tube.

Mounting Method Standard flat mount using an eight bolt hole pattern with oil discharge through a 4" n.p.t. (10 cm) pipe fitting.

Weight Drive assembly and housing with motor, without collector tube: 74 lbs. (34 kg)
Collector tube weight determined by its length.

Options 4 ft. (1.2 m) vertical mounting stand.

304 stainless steel construction.

Float switch with signal light (fits 3/4" drum bung) to prevent discharge drum overflow.

Timer and electrical controls.

Wiper Rings	Temperature of Liquid	pH 3-5 (acidic)	pH 6-8 (neutral)	pH 9-14 (alkaline)
	33F-175F (.05°C-80°C)	CRV	CRV Nitrile	CRV Nitrile
	175F-212F (80°C-100°C)	CRV	CRV	CRV
Tubes	Temperature of Liquid	pH 3-5 (acidic)	pH 6-8 (neutral)	pH 9-14 (alkaline)
	33F-175F (.05°C-80°C)	Super Poly	Poly	Super Poly
	175F-212F (80°C-100°C)	Super Poly	Super Poly	Super Poly

ABANAKI

OIL SKIMMERS

USA: 17387 Munn Road, Chagrin Falls, Ohio 44023

800-358-SKIM (7546) (440)543-7400 FAX: (440)543-7404

UK: Unit 13 Avondale Business Center Woodland Way Bristol BS15 1AW
0117 9616679 FAX: 0117 9616687

www.abanaki.com